

CLARKPRO[®]

METALWORKER



BENCH GRINDER WITH SANDING BELT

MODEL NO: CBG6SC

PART NO: 6502130

OPERATING & MAINTENANCE INSTRUCTIONS



ORIGINAL INSTRUCTIONS

DL06/23 - Rev 2

INTRODUCTION

Thank you for purchasing this CLARKE Bench Grinder with sanding belt.

Before attempting to use this product, please read this manual thoroughly and follow the instructions carefully. In doing so you will ensure the safety of yourself and that of others around you, and you can look forward to your purchase giving you long and satisfactory service.

GUARANTEE

This product is guaranteed against faulty manufacture for a period of 12 months from the date of purchase. Please keep your receipt which will be required as proof of purchase.

This guarantee is invalid if the product is found to have been abused or tampered with in any way, or not used for the purpose for which it was intended.

Faulty goods should be returned to their place of purchase, no product can be returned to us without prior permission.

This guarantee does not effect your statutory rights.

ENVIRONMENTAL PROTECTION



Do not dispose of this product with general household waste. All tools, accessories and packaging should be sorted, taken to a recycling centre and disposed of according to the laws governing Waste Electrical and Electronic Equipment.

Through the purchase of this product, the customer is taking on the obligation to deal with the WEEE in accordance with the WEEE regulations in relation to the treatment, recycling & recovery and environmentally sound disposal of the WEEE.

In effect, this means that this product must not be disposed of with general household waste. It must be disposed of according to the laws governing Waste Electrical and Electronic Equipment (WEEE) at a recognised disposal facility.

GENERAL SAFETY RULES



CAUTION: FAILURE TO FOLLOW THESE PRECAUTIONS COULD RESULT IN PERSONAL INJURY, AND/OR DAMAGE TO PROPERTY. PLEASE KEEP THESE INSTRUCTIONS IN A SAFE PLACE FOR FUTURE REFERENCE.

WORK ENVIRONMENT

1. Keep the work area clean, tidy and well lit. Cluttered and dark areas invite accidents
2. DO NOT operate power tools in explosive atmospheres, such as in the presence of flammable liquids, gases or dust. Power tools create sparks which may ignite the dust or fumes.
3. Keep children and bystanders away while operating a power tool. Distractions can cause you to lose control.

PERSONAL SAFETY

1. Stay alert, watch what you are doing and use common sense when operating a power tool. DO NOT use a power tool while you are tired or under the influence of drugs, alcohol or medication. A moment of inattention while operating power tools may result in personal injury.
2. AVOID accidental starting. Ensure the switch is in the off position before plugging in. Plugging in power tools that have the switch on invites accidents.
3. DO NOT overreach. Keep proper footing and balance at all times. This enables better control of the power tool in unexpected situations.
4. Dress properly. DO NOT wear loose clothing or jewellery. Keep your hair, clothing and gloves away from moving parts. Loose clothes, jewellery or long hair can be caught in moving parts.
5. Eye protection manufactured to the current European safety standards should be worn when operating grinding equipment. Eye protectors must provide protection from flying particles from the front and the side.

GENERAL USE AND CARE OF POWER TOOLS

1. ALWAYS check for any damage or condition that could affect the grinder's operation. Any damaged part should be properly repaired.
2. NEVER use the grinder if it is defective or operating abnormally.
3. NEVER abuse the mains cable. Never yank the cable to disconnect it from the socket. Keep the cable away from sharp edges/hot surfaces.

4. NEVER carry out any alterations or modifications to this product.
5. NEVER wipe the machine clean with solvents. Wipe plastic parts with a soft cloth, slightly dampened with soapy water.
6. NEVER attempt any repairs yourself. If you have a problem with this product contact your local CLARKE dealer.
7. DO NOT use the tool for any purpose than that described in this manual.
8. ALWAYS maintain the tool with care. Keep it clean for the best and safest performance.
9. DO NOT force the power tool. Use the correct power tool for your application. The correct power tool will do the job better and safer at the rate which it was designed.
10. DO NOT use the power tool if the switch does not turn it on and off. Any power tool that cannot be controlled with the switch is dangerous and must be repaired.
11. Store idle tools out of the reach of children and DO NOT allow persons unfamiliar with the power tool or these instructions to operate the power tool. Power tools are dangerous in the hands of untrained users.
12. Maintain power tools. Check for misalignment or binding of moving parts, breakage of parts and any other condition that may affect the power tools operation. If damaged, have the power tool repaired before use. Many accidents are caused by poorly maintained power tools.
13. Use the power tool and accessories in accordance with these instructions and in the manner intended for the particular type of power tool, taking into account the working conditions and the work to be performed. Use of the power tool for operations different from intended could result in a hazardous situation.

ELECTRICAL SAFETY

1. Power tool plugs must match the outlet. NEVER modify the plug in any way. DO NOT use adapter plugs with earthed (grounded) power tools. Correct plugs and matching outlets will reduce the risk of electric shock.
2. DO NOT abuse the cable. NEVER use it for carrying, pulling or unplugging the power tool. Keep the cable away from heat, oil, sharp edges or moving parts. Damaged or entangled cables increase the risk of electric shock.
3. DO NOT expose power tools to rain or wet conditions. Water entering a power tool will increase the risk of electric shock. If operating the power tool in a damp location is unavoidable, use a residual current device (RCD) protected supply.

4. When operating a power tool outdoors, use an extension cable suitable for outdoor use. Use of a cable suitable for outdoor use reduces the risk of electric shock.

BELT/DISC SANDER SAFETY

1. ALWAYS wear a dust mask when using this machine. Be aware that harmful or toxic dusts could be produced when sanding some woods.
2. ALWAYS use the table to support the workpiece.
3. ALWAYS check to ensure the attachments are secure before starting.
4. ALWAYS maintain a suitable clearance between table and sanding belt.
5. ALWAYS hold the workpiece firmly so that it cannot be torn from your hands
6. ALWAYS ensure that nails or foreign objects have been removed from a workpiece beforehand. Nails etc. will destroy the belt.
7. NEVER sand pieces which cannot be held firmly by hand.

GRINDING STONE SAFETY

1. Check the speed of the grindstone before fitting to your grinder. NEVER use a stone with a rpm speed less than the rpm speed of your grinder.
2. The outside diameter and thickness of your accessories must be within the capacity rating of the power tool. The correct size accessories can be correctly guarded and controlled.
3. NEVER use a stone that is chipped, cracked or damaged. Fragments from a broken or damaged grinding stone can cause serious injury. Make sure that defective stones are destroyed and not used.
4. Bonded abrasive products are breakable and shall therefore be handled with utmost care. The use of damaged or improperly mounted or used abrasive products is dangerous and can cause serious injuries.
5. ALWAYS refer to the label for specified usage and observe the safety information. DO NOT use for purposes other than specified.
6. ALWAYS use the correct stone for it's intended task. Using the incorrect stone can cause serious injury.
7. Allow the stone and tool to do the work. NEVER force the workpiece against the stone as this could cause kickback and/or shatter the stone causing serious injury.
8. NEVER use a damaged grinding stone. Inspect the stone before each use for chips, cracks or excess wear. If the tool or accessory is dropped, inspect for damage or install a new accessory. After fitting the accessory, position yourself away from the plane of the rotating accessory and run the tool at full speed. Damaged stones may break apart during this test.

9. Abrasive products shall be handled and transported with care. Abrasive products shall be stored in such a manner that they are not subjected to mechanical damage and harmful environmental influences.
10. DO NOT use separate reducing bushes or adapters to adapt large hole abrasive wheels. DO NOT force a stone onto a machine or alter the size of the arbor hole.

BENCH GRINDER SAFETY WARNINGS

1. Hold ANY tool or blade being sharpened firmly to prevent loss of control.
2. NEVER install a abrasive flap wheel or sanding disc on this grinder.
3. ALWAYS replace a cracked grinding wheel immediately.
4. NEVER use damaged or incorrect grindstones. The stone and retaining fixtures were specially designed for your grinder, for optimum performance and safety of operation. Inspect the condition of the grinding stone before use and do not use if any damage is found.
5. ALWAYS use the tool rests to steady the workpiece, the torque of the spinning grinding wheel may pull the workpiece from your hands.
6. ALWAYS check for damaged parts. Before further use any part that is damaged should be carefully checked to determine if it would operate properly and perform its intended function. Check for misalignment or binding of moving parts, breakage of parts and any other condition that may affect the tool's operation. A part that is damaged should be properly repaired or replaced at an authorised service center. Following this rule will reduce the risk of electric shock, fire or serious injury.

NOTE: Bench grinders used in industrial environments may be subject to the The Provision and Use of Work Equipment regulations 1992 and/or the training requirement of The Abrasive Wheels Regulations 1970), or other legislation. If in doubt seek advice

SAFETY SYMBOLS

The meanings of the markings and symbols on the product are shown below

| | | | |
|---|---|---|---|
|  | Read this manual before use and keep in a safe place for future reference |  | Wear eye protection when using this tool. |
|  | Wear ear protection |  | Wear dust mask. |

ELECTRICAL CONNECTIONS



WARNING! READ THESE ELECTRICAL SAFETY INSTRUCTIONS THOROUGHLY BEFORE CONNECTING THE PRODUCT TO THE MAINS SUPPLY.

Before switching the product on, make sure that the voltage of your electricity supply is the same as that indicated on the rating plate. This product is designed to operate on 230VAC 50Hz. Connecting it to any other power source may cause damage.

This product may be fitted with a non-rewireable plug. If it is necessary to change the fuse in the plug, the fuse cover must be refitted. If the fuse cover becomes lost or damaged, the plug must not be used until a suitable replacement is obtained.

If the plug has to be changed because it is not suitable for your socket, or due to damage, it should be cut off and a replacement fitted, following the wiring instructions shown below. The old plug must be disposed of safely, as insertion into a mains socket could cause an electrical hazard.

If the colours of the wires in the power cable of this product do not correspond with the markings on the terminals of your plug, proceed as follows.

- The **Blue** wire must be connected to the terminal marked **N** or coloured **Black**.
- The **Brown** wire must be connected to the terminal marked **L** or coloured **Red**.
- The **Yellow and Green** wire must be connected to the terminal marked **E** or  or coloured **Green**.

Plug must be BS1363/A approved.

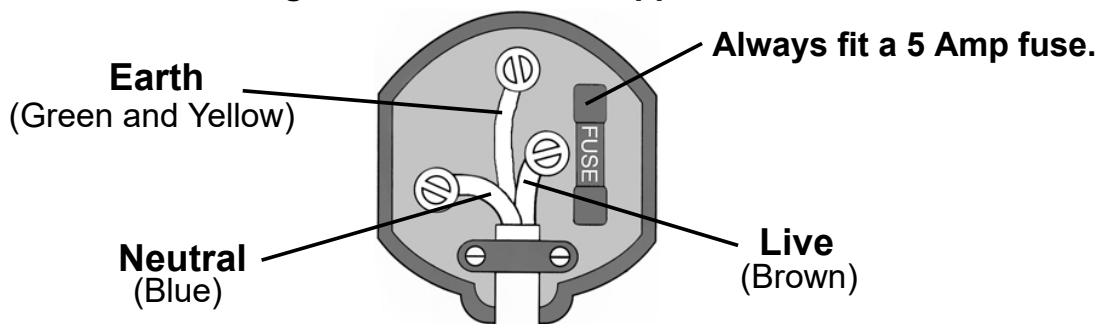

Ensure that the outer sheath of the cable is firmly held by the clamp

We strongly recommend that this machine is connected to the mains supply via a Residual Current Device (RCD). If in any doubt, consult a qualified electrician. DO NOT attempt any repairs yourself.

OVERVIEW

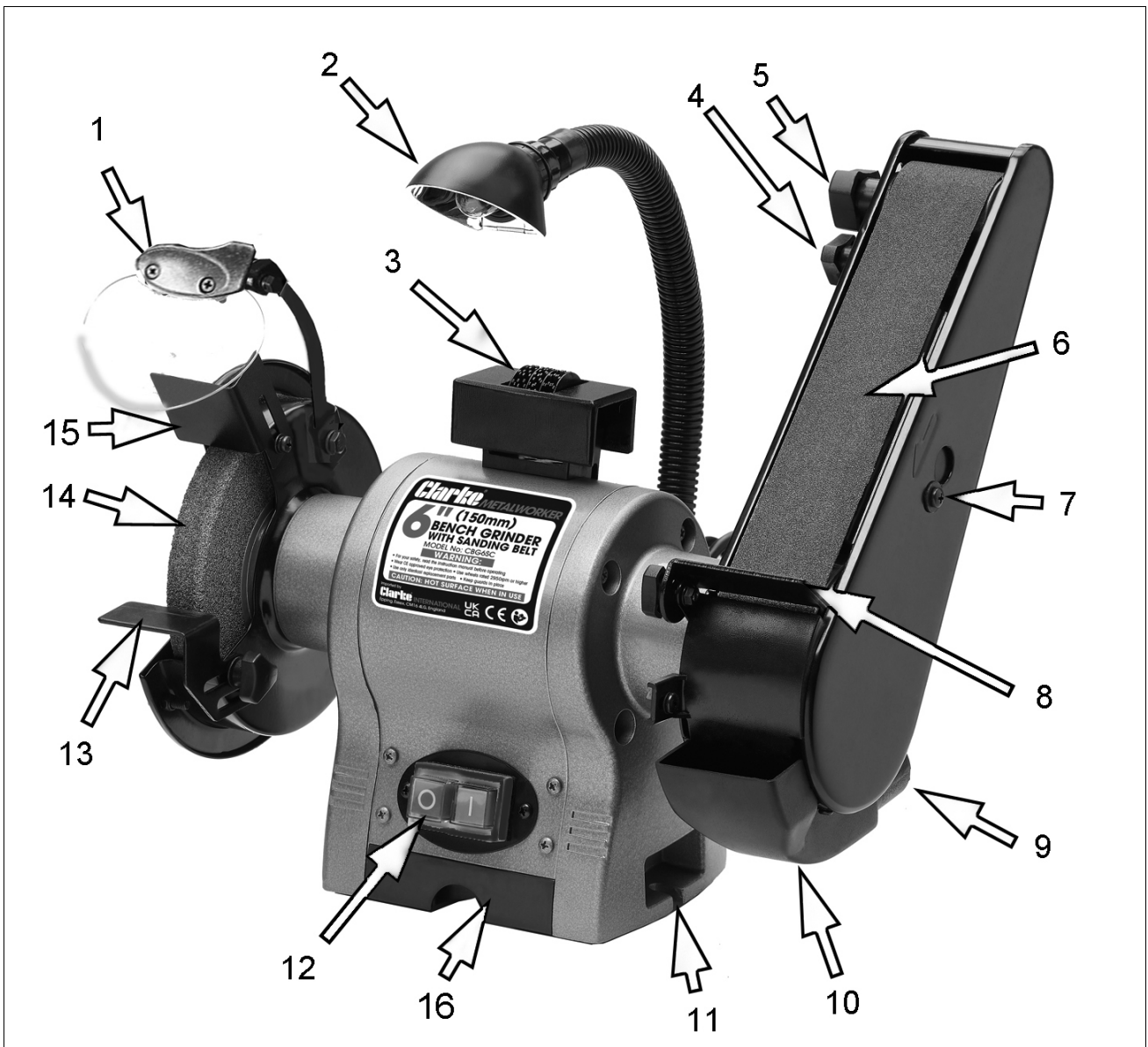

| No | Description |
|----|-------------------------------|
| 1 | Eye Shield |
| 2 | Flexible Lamp |
| 3 | Grinding Wheel Dresser |
| 4 | Belt Tracking Adjustment Knob |
| 5 | Belt Tension Knob |
| 6 | Sanding Belt |
| 7 | Side Guard Release Screw |
| 8 | Sanding Workpiece Rest |

| No | Description |
|----|---------------------------|
| 9 | Dust Extract Port |
| 10 | Dust Collector/Belt guard |
| 11 | Mounting Bolt Location |
| 12 | On/Off Switch |
| 13 | Tool Rest |
| 14 | Grinding Wheel |
| 15 | Spark Deflector |
| 16 | Coolant Tray |

ASSEMBLY

INVENTORY

The machine is supplied with the following items. If any items are missing or damaged, please contact the dealer where you purchased the product.

- 1 x Eye Guard
- 2 x Tool Rests (1x grinding/ 1 x sanding)
- 1 x Spark Deflector
- 1 x Grinding Wheel (fitted)
- 1 x Sanding Belt (fitted)
- 1 x Wheel Dresser
- 1 x Wrench

MOUNTING THE MACHINE ON A WORKBENCH

NOTE: We highly recommend that you bolt this machine securely to a workbench to gain maximum stability.

1. Using the base of the machine as a template, mark and drill the workbench at the positions of the mounting holes in the base.
2. Bolt the bench grinder to the bench with suitable bolts, washers and nuts (not supplied).

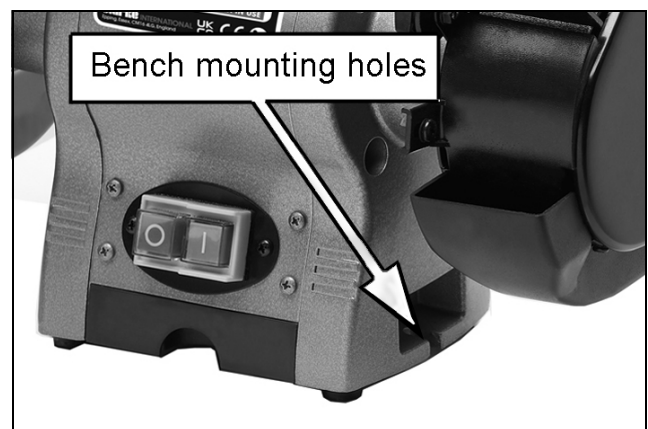

FITTING THE GRINDING WHEEL TOOL REST

1. Fix the tool rest to the bench grinder with the wingnut as shown.
 - The tool rest is adjustable and should be positioned as close as practical to the grinding wheel.
 - Ensure that the tool rest is firmly fixed and horizontal.



FITTING THE SPARK DEFLECTOR

Fit the spark deflector to the grinding wheel guard using the screw and washers provided.

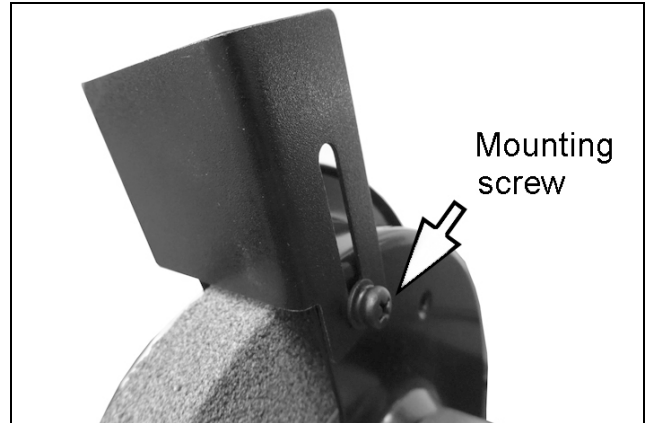

FITTING THE EYESHIELD

Fit the eyeshield to the grinding wheel guard using the support arm, bolt and washers provided.

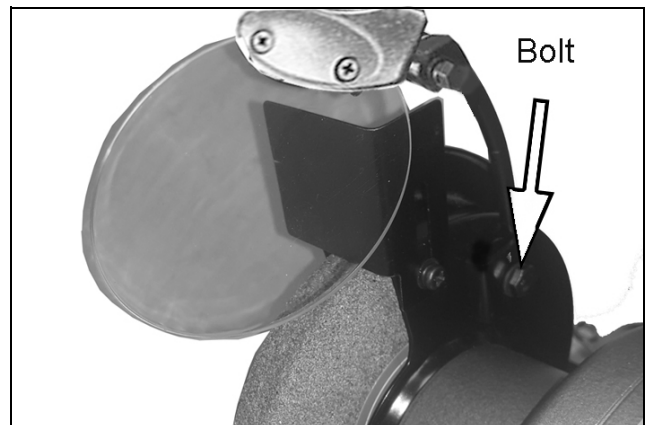

FITTING THE SANDING WORK REST

Fit the work rest to the sanding belt guard using the plastic wingnut, nut and washer provided.

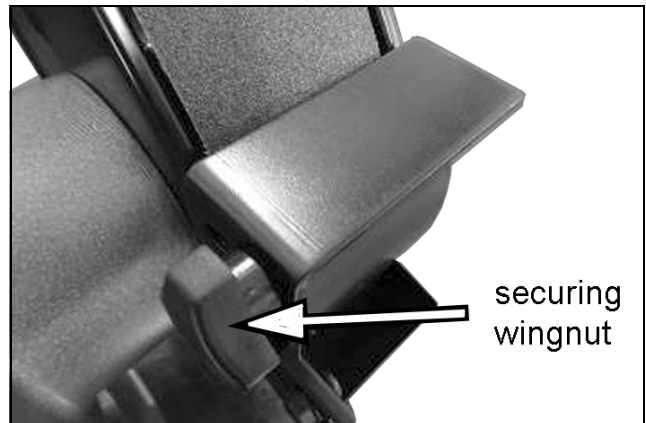

FITTING THE DRESSING TOOL

Mount the dressing wheel on the bracket on top of the machine.



USING THE MACHINE FOR GRINDING



WARNING: FRAGMENTS FROM A BROKEN/DETACHED GRINDING WHEEL CAN CAUSE INJURY.

WARNING: ENSURE THAT THE WORKING POSITION ADOPTED DOES NOT CAUSE OPERATOR FATIGUE WHICH MAY LEAD TO LOSS OF CONTROL OF THE TOOL BEING GROUND.

WARNING: THE GRINDING WHEEL WILL CONTINUE TO ROTATE BRIEFLY AFTER THE OFF SWITCH HAS BEEN PRESSED.

SETTING THE SPARK DEFLECTOR AND EYE SHIELD

1. Slacken the spark arrestor securing screw and position the arrestor so that the bottom edge is adjacent to the wheel, with a clearance of approximately 2 mm. Tighten the screw to secure in position.
2. Secure the eye shield in position. The eye shield should be a tight enough fit on its mounting that it does not move under operational vibration, but loose enough so that it may easily be positioned by hand.
3. Check the grinding wheel guard and make any adjustments necessary before use.

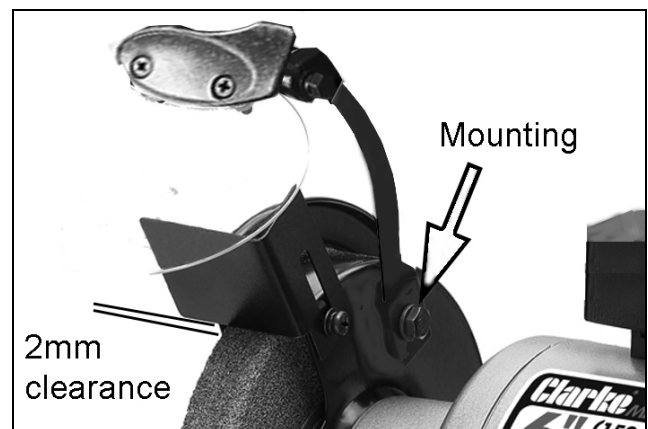

SETTING THE TOOLREST

1. Slacken the tool rest securing knob and position the rest so that it is adjacent to the grinding wheel with a clearance of approximately 2 mm. Tighten the bolt to secure in position.
 - NEVER attempt to grind a piece of metal that is thinner than the gap between the tool rest and the grinding wheel.

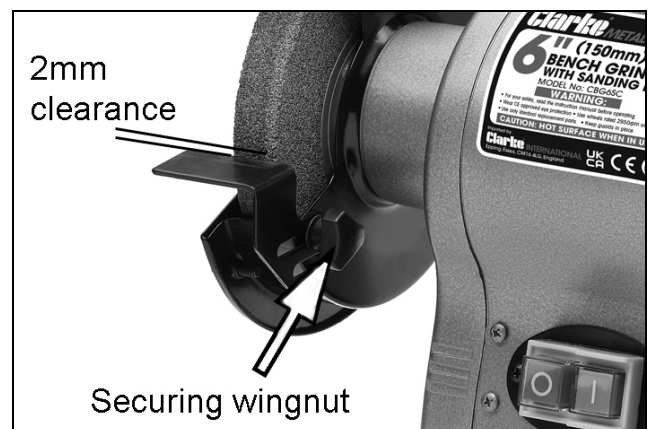

USING THE GRINDING WHEEL



WARNING: APPLYING EXCESSIVE FORCE TO THE GRINDING WHEEL CAN BE DANGEROUS AND COULD CAUSE DAMAGE TO THE MACHINE. NEVER ATTEMPT TO USE THE SIDE OF THE GRINDING WHEEL.

1. Turn the grinding wheel by hand to ensure it is free, then switch ON by pushing the switch so that the "I" is depressed. To switch OFF push the switch so that the "O" is depressed.
2. Press the workpiece to be ground, evenly onto the grinding stone and move the workpiece sideways across the stone. Make sure that at least half the width of the workpiece always presses on the grinding stone at any time to avoid damage to the stone.
3. Allow the machine to do the work. DO NOT apply excessive pressure on the tool when grinding or to the belt when sanding
4. The clearance between the grinding wheel and tool rest should be maintained. If the clearance gap is greater than the thickness of the metal being ground there is a danger that the force of grinding will cause the work piece to be pulled into the gap and is potentially dangerous. An incorrect gap could also cause "chatter" which could result in damage to the wheel.
5. The plastic tray can be used to contain coolant for use during grinding.

SHARPENING TIPS

SCISSORS

If possible, take the scissors apart to make the sharpening operation easier and safer. Remove material only from the outside surface and work from the handle end of the blade towards the tip.

KNIVES

Remove metal equally from both faces, working from the handle end of the blade towards the tip.

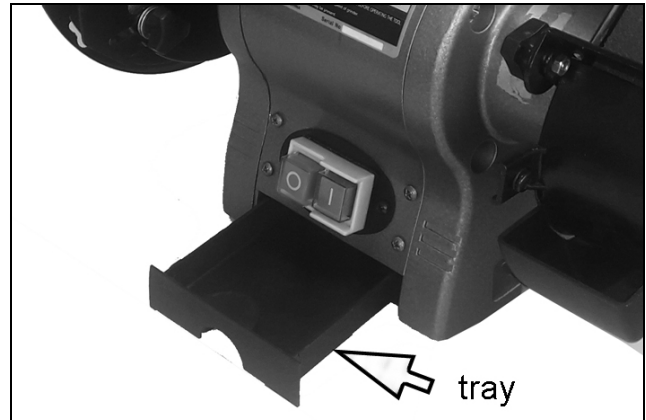

USING THE BUILT IN LIGHT

The built in light will come on whenever the machine is switched on.

The arm can be adjusted to set the light in the most suitable position.

USING THE MACHINE FOR SANDING



WARNING: ENSURE THAT THE WORKING POSITION ADOPTED DOES NOT CAUSE OPERATOR FATIGUE WHICH MAY LEAD TO LOSS OF CONTROL OF THE WORKPIECE BEING SANDED.

WARNING: THE SANDING BELT WILL CONTINUE TO ROTATE BRIEFLY AFTER THE OFF SWITCH HAS BEEN PRESSED.

SETTING THE SANDER WORK REST

Slacken the wingnut that secures the work rest in place and position the rest so that it is adjacent to the belt edge and at 90 degrees to the belts surface with approximately 2 mm clearance. Tighten the wingnut to secure in position.

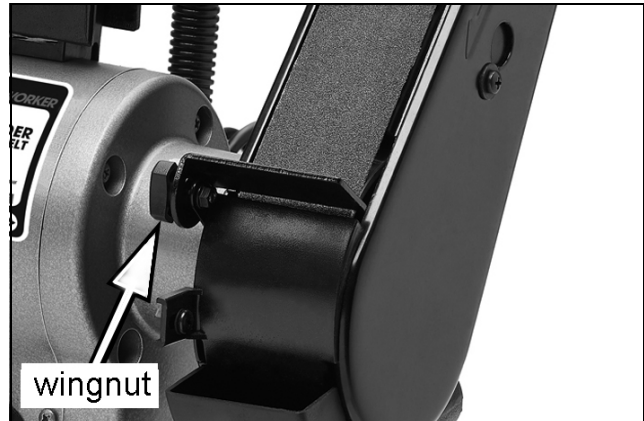

USING THE SANDING BELT

1. Switch the motor ON by pushing the switch so that the "1" is depressed, and allow the machine to reach full speed. To switch the motor OFF push the switch so that the "0" is depressed.
2. Hold the workpiece firmly on the work rest and apply slight pressure to the sanding belt, allowing the machine to do the work.

MAINTENANCE

GENERAL MAINTENANCE

Make sure that all components are tight and secure. ALWAYS have any damaged or worn parts repaired or replaced by qualified service personnel. DO NOT attempt to repair the bench grinder unless you are qualified to do so.

The drive motor and bearings are sealed units and require no regular maintenance. Should you require assistance, contact your service agent.

The grinding stone will wear down with use and may well go out of true. Use the dressing wheel or stone grader to correct the trueness and to remove worn, glazed areas from the stone.

The stone will have a finite life expectancy dependant upon the nature of the work being done. Periodically, make a note of the wheel diameter and replace the (150mm dia) wheel if it reduces to as little as (130mm) in diameter.

INSTALLING A NEW GRINDING WHEEL



WARNING: NEVER OPERATE THE GRINDING WHEEL WITHOUT THE GUARD FITTED IN POSITION.

To renew or change the grinding wheels, proceed as follows.

1. Switch off and un-plug from power supply. Remove the grinding wheel cover by loosening the three retaining screws and twisting the guard anti-clockwise to disengage it from the machine.



2. Hold or jam the sanding belt roller to stop the drive shaft rotating and remove the nut and retaining disc securing the grinding wheel, remembering that the nut has a LEFT HAND THREAD.

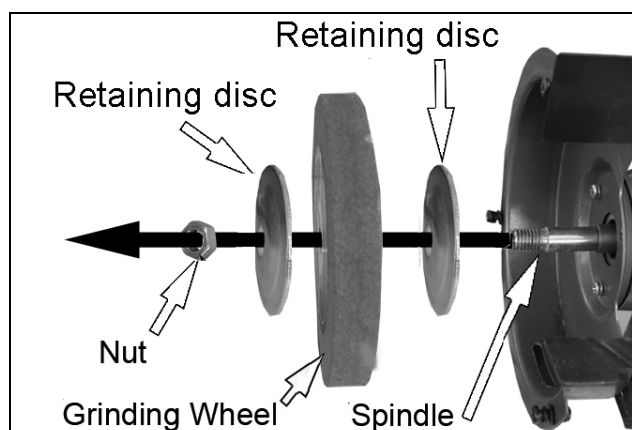

3. Remove the used wheel and replace with a new one.
 - DO NOT overtighten the wheel retaining nut.

4. Refit the grinding wheel cover and re-adjust the tool rest and spark arrester brackets to suit the new wheel.

5. Switch the machine on and allow it to rotate freely for at least one minute

DRESSING A NEW STONE

New grinding stones are frequently not true, or in time can become grooved, glazed (built-up), out of round, or otherwise mis-shapen. To correct these defects, a grinding stone dresser is supplied with the machine. Further items are available from your CLARKE dealer.

- ET125 Grinding Wheel Dresser - Part No:1700225
- ET154 ½ Carat Diamond Tip Wheel Dresser - Part No:1700329

1. If the grinding stone is new, allow it to spin for a minute with no load. Check that it is spinning straight and true. If not, it will require dressing before use.

2. Stand to the side of the stone and hold the dresser handle firmly. Place the dresser on the tool support so that its wheels can move freely (i.e, the exposed part of the wheel should be facing up). Run the stone and apply the dresser to the surface of the stone.
3. When the abrasive wheel starts to become clogged with debris, use the dresser tool supplied to clean (dress) it

CHANGING THE SANDING BELT

To renew or change the sanding belt proceed as follows:

1. Unplug from the power supply. Remove the sander side cover by unscrewing the securing screw.
2. Slacken the top roller securing wingnut, allowing the top roller to move slightly off its axis as shown.
3. Slide the belt off and replace with a new one, ensuring it lies centrally on the top and bottom rollers
4. Retighten the top roller securing wingnut till it becomes firm but NOT too tight. The belt should now be fairly taught and positioned centrally on the rollers.

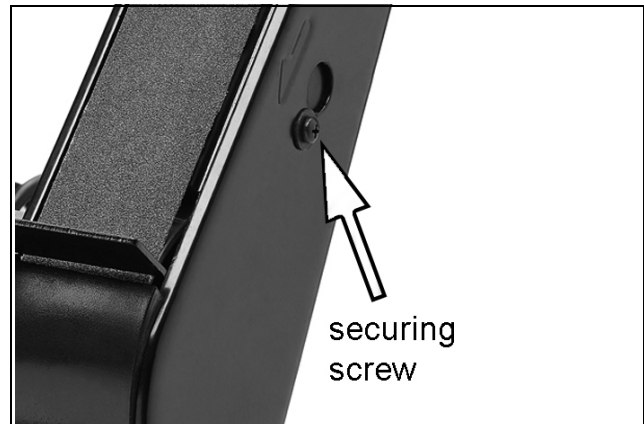

IMPORTANT: The belt needs just enough tension to ensure that it does not slip on the rollers whilst under load, however too much tension will shorten the working life of the belt and the machine.

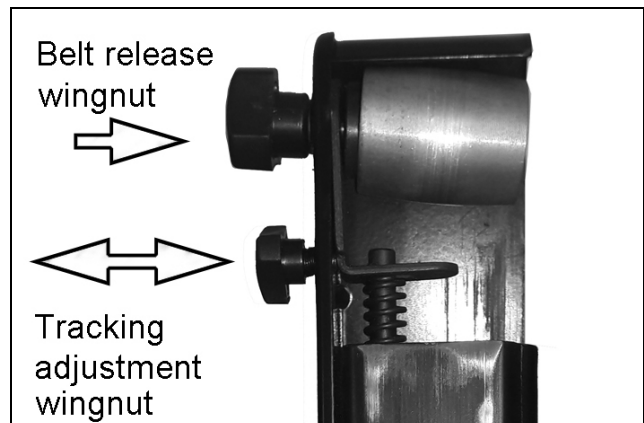

5. Replace the sanding belt cover.
6. Rotate the belt by hand whilst screwing the Tracking Adjustment screw in or out to ensure the belt runs centrally on the rollers. Turn the screw anticlockwise to move the belt outwards (towards the outer cover), or clockwise to move inwards.
7. When satisfied, plug the machine into the power supply and switch on. Make fine adjustments with the Tracking Adjustment screw if necessary.

CLEANING & STORAGE

Clean the exterior of the machine if required using a mild detergent or mild solvent. NEVER immerse the machine in water. To reduce any fire hazard, keep

any cooling vents clear. If not bolted to a workbench, store the grinder in a clean, dry location, out of reach of children.

ACCESSORIES

| Description | Part No |
|-------------------------------------|---------|
| Grinding Wheel - Fine (1/2" bore) | 6501043 |
| Grinding Wheel - Medium (1/2" bore) | 6501044 |
| Grinding Wheel - Coarse (1/2" bore) | 6501045 |
| Grinding Wheel Dressing Tool - GWD1 | 6501120 |
| Sanding Belts - Fine (pack of 5) | 6502115 |
| Sanding Belts - Medium (pack of 5) | 6502120 |
| Sanding Belts - Coarse (pack of 5) | 6502125 |
| Bench Grinder Stand CBGS2 | 6501142 |

TROUBLESHOOTING

| Problem | Possible Cause | Action |
|--------------------------------------|---|---|
| Motor doesn't start | a) ON/OFF switch damaged b) Switch cable damaged c) ON/Off relay damaged d) Fuse blown e) Motor burnt out | a-d) Replace all damaged parts before using the machine. e) Contact your service centre to have machine repaired by a skilled technician |
| Machine gets slower during work | Too much pressure on the workpiece | Reduce pressure on the workpiece |
| Sanding belt comes off drive pulleys | Belt does not run straight | Reset the tracking and tensioner |
| Wood gets burnt during sanding | a) Sanding belt dirty b) excessive pressure on the workpiece | a) Replace belt b) Reduce pressure on work piece |

COMPONENT PARTS

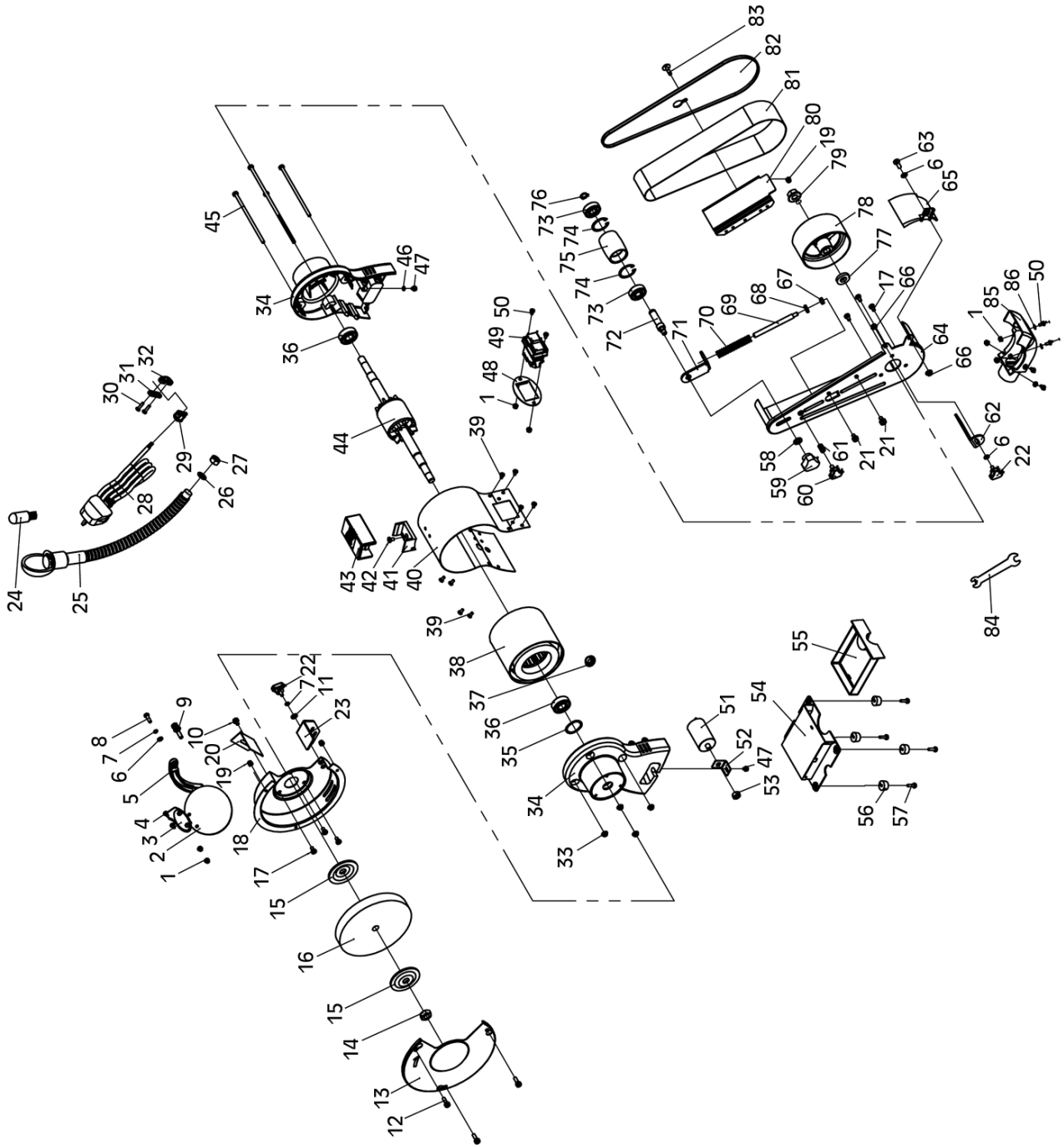

COMPONENT PARTS

| No | Description |
|----|---------------------------------------|
| 1 | Nut M4 with flange |
| 2 | Eye shield |
| 3 | Shield mounting plate |
| 4 | Screw M4x11 |
| 5 | Eye shield support |
| 6 | Washer |
| 7 | Spring washer |
| 8 | Bolt M5x16 |
| 9 | Bolt M6x30 & spring washer |
| 10 | Screw M5x8 & spring washer/ washer |
| 11 | Washer |
| 12 | Screw M5x18 & spring washer |
| 13 | Left shield cover plate |
| 14 | Nut M12 |
| 15 | Retaining disc |
| 16 | Grinding stone |
| 17 | Screw M5x10 & spring washer |
| 18 | Inner hood guard |
| 19 | Lock nut M5 |
| 20 | Spark baffle |
| 21 | Screw M5x10 & springwasher |
| 22 | Bracket locking knob M5x10 |
| 23 | Tool rest (grindstone) |
| 24 | Lightbulb -12V/10W |
| 25 | Spiral lamp assembly |
| 26 | Washer |
| 27 | Thin nut M10x1 |
| 28 | Power cable |
| 29 | Cable grommet |
| 30 | Screw M4x16 |

| No | Description |
|----|------------------------------|
| 31 | Cable clamp backing plate |
| 32 | Cable clamp plate |
| 33 | Hex nut M5 with flange |
| 34 | End cover |
| 35 | Wave spring D35 |
| 36 | Bearing 6202-2RZ |
| 37 | Cable gland |
| 38 | Stator |
| 39 | Screw M4x8 |
| 40 | Motor housing |
| 41 | Dressing tool holder |
| 42 | Screw M5x8 |
| 43 | Dressing tool |
| 44 | Rotor |
| 45 | Long bolt and washer M5x131 |
| 46 | External teeth lockwasher |
| 47 | Screw M4x7 & springwashers |
| 48 | Switch baseplate |
| 49 | On/off switch |
| 50 | Screw M4x8 |
| 51 | Capacitor 6UF/450V |
| 52 | Capacitor support |
| 53 | Nut M8 |
| 54 | Coolant tray baseplate |
| 55 | Coolant tray |
| 56 | Rubber foot |
| 57 | Screw M4x16 & washer |
| 58 | Washer |
| 59 | Locking knob M8 |
| 60 | Sanding belt adjustment knob |

COMPONENT PARTS

| No | Description |
|----|------------------------|
| 61 | Belt alignment spring |
| 62 | Toolrest (Sanding) |
| 63 | Screw M5x12 |
| 64 | Right guard inner hood |
| 65 | Sanding belt guard |
| 66 | Hex nut M5 with flange |
| 67 | Hex nut M6 |
| 68 | Thin nut M8 |
| 69 | Adjusting rod |
| 70 | Compression spring |
| 71 | Tensioning plate |
| 72 | Driven shaft |
| 73 | Bearing 6201-2RZ |

| No | Description |
|----|-------------------------|
| 74 | Circlip |
| 75 | Driven roller |
| 76 | Circlip |
| 77 | Spacer bush |
| 78 | Driver |
| 79 | Hex nut M12 with flange |
| 80 | Belt platten |
| 81 | Belt |
| 82 | Right cover plate |
| 83 | Screw M5x20 & washer |
| 84 | Wrench 8x10 |
| 85 | Dust extract hood |
| 86 | Washer |

PRODUCT SPECIFICATIONS

| Feature | Value |
|---------------------------|--|
| Overall Dimensions (mm) | 390 (H) x 290 (W) x 350 (D) |
| Weight | 10.25 kg |
| Grinding Stone Dimensions | 150 dia x 20 mm thickness (12.7 mm bore) |
| Rated Voltage / Frequency | 230 V / 50 Hz |
| Motor Wattage | S1: 250W, S2: 30 mins 370W |
| No Load Speed | 2980 rpm |
| Duty Cycle Classification | S2 (30 minutes on in any 60 minutes) |
| No load belt speed | 15.6 m/s |
| Belt Length | 686 mm |
| Belt Width | 50 mm |

DECLARATION OF CONFORMITY-UK



Hemnall Street, Epping, Essex CM16 4LG

DECLARATION OF CONFORMITY

This is an important document and should be retained.

We hereby declare that this product(s) complies with the following statutory requirement(s):

Electromagnetic Compatibility Regulations 2016

Supply of Machinery (Safety) Regulations 2008

The Restriction of the Use of Certain Hazardous Substances in Electrical and Electronic Equipment Regulations 2012

The following standards have been applied to the product(s):

EN 55014-1:2017, EN 55014-2:2015, EN IEC 61000-3-2:2019, EN 61000-3-3:2013+A1:2019,

IEC 62841-1:2014, EN 62841-14:2015, IEC 62841-3-4:2016+A1:2019,

EN 62841-3-4:2016+A11:2017+A12:2020, EN 62321-1:2013, EN 62321-2:2014, EN 62321-3-1:2014,

EN 62321-4:2014, EN 62321-5:2016, EN 62321-6:2015, EN 62321-7-1:2015, EN 62321-7-2:2017,

EN 62321-8:2017

The technical documentation required to demonstrate that the product(s) meet(s) the requirement(s) of the aforementioned legislation has been compiled and is available for inspection by the relevant enforcement authorities.

The UKCA mark was first applied in: 2022

| | |
|-------------------------------|---------------------------------|
| Product Description: | Bench Grinder with Sanding Belt |
| Model number(s): | CBG6SC |
| Serial / batch Number: | N/A |
| Date of issue: | 02/08/2022 |

Signed:

J.A. Clarke
Director

DECLARATION OF CONFORMITY-CE



Clarke[®]
INTERNATIONAL

Fitzwilliam Hall, Fitzwilliam Place, Dublin 2

DECLARATION OF CONFORMITY

This is an important document and should be retained.

We hereby declare that this product(s) complies with the following directive(s):

- 2014/30/EU *Electromagnetic Compatibility Directive*
- 2006/42/EC *Machinery Directive*
- 2011/65/EU *Restrictions of the Use of Certain Hazardous Substances in Electrical and Electronic Equipment Directive*

The following standards have been applied to the product(s):

- EN 55014-1:2017, EN 55014-2:2015, EN IEC 61000-3-2:2019, EN 61000-3-3:2013+A1:2019,
- IEC 62841-1:2014, EN 62841-14:2015, IEC 62841-3-4:2016+A1:2019,
- EN 62841-3-4:2016+A11:2017+A12:2020, EN 62321-1:2013, EN 62321-2:2014, EN 62321-3-1:2014,
- EN 62321-4:2014, EN 62321-5:2016, EN 62321-6:2015, EN 62321-7-1:2015, EN 62321-7-2:2017,
- EN 62321-8:2017

The technical documentation required to demonstrate that the product(s) meet(s) the requirement(s) of the aforementioned directive(s) has been compiled and is available for inspection by the relevant enforcement authorities.

The CE mark was first applied in: 2022

Product Description: Bench Grinder with Sanding Belt
Model number(s): CBG6SC
Serial / batch Number: N/A
Date of Issue: 02/08/2022

Signed:

J.A. Clarke
Director

USEFUL CLARKE PRODUCTS



CFWB1 Folding Workbench

- 770mm working height
- Supports loads up to 150kg



CSM5100BL 100kg Boltless Steel Shelving

- Tough steel frame
- Quick and easy assembly
- Dims (WxDxH): 900 x 400 x 1800mm



CMFT220 Multi Tool with Accessory Kit

- Includes sanding pad, 3 sanding sheets, 2 cutting blades, scraper blade & side handle for extra control



CMFT300QR Multi Tool with Quick Release & Accessory Kit

- Includes sanding pad, 3 sanding sheets, 2 cutting blades & scraper blade



CONSN18LiC 18V Li-ion Nailer/Stapler

- Average drive speed: 60 nails/min
- 18V 2.0Ah power pack
- Includes battery charger & carrying case



CR1200 1200W Router

- Maximum plunge depth: 55mm
- Dust extraction facility



CMPS2 Multi-Purpose Sharpener

- Sharpens 3 - 10mm drills, 6 - 51mm wide chisels & plane blades



SV2 Clear Moulded Flip Visor

- Full face visor
- Conforms to EN66



CWL1000B 1000mm Wood Lathe

- 4 speed
- Includes tool rest, tail stock, drive centre, face plate & 3 chisels

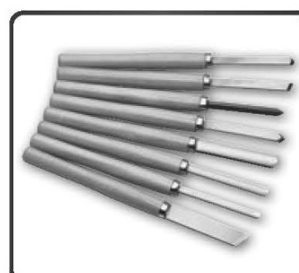

CHT874 8 Piece Wood Turning Chisel Set

- Coated wooden handles
- Hardened and tempered steel blades



CMS250S 250mm Sliding Mitre Saw

- Max. depth of cut: 85mm
- Max. cross cut capacity: 250mm
- Laser cutting guide



CMS210S 210mm Sliding Mitre Saw

- Max depth of cut 210mm
- Laser cutting guide

USEFUL CLARKE PRODUCTS

| | |
|---|---|
| <p align="center">CWVE1 DUST EXTRACTOR</p> | <p align="center">CDS300B 12" (305mm) DISC SANDER</p> |
|  <ul style="list-style-type: none"> • Tank capacity 50 litres • 100mm(dia)x2m(length) inlet hose • Inlet adaptor set <p align="right">Part No. 6471168</p> |  <ul style="list-style-type: none"> • 305mm disc diameter (1 x60 grit sanding disc included) • Table 437x153mm • Dust extraction diameter: 51mm (outer), 46mm (inner) - 20mm reduction adaptor included <p align="right">Part No. 6500411</p> |
| <p align="center">CBS2 'CONTRACTOR' BELT SANDER (230v)</p> | <p align="center">CR2 - 2100W ROUTER & KIT (230v)</p> |
|  <ul style="list-style-type: none"> • 1200 watt, 230v motor • 100x610mm belt size (1 included) • 480 mtrs/min. belt speed • Belt alignment control • Dust extraction port and zipped collecting bag <p align="right">Part No. 6462080</p> |  <ul style="list-style-type: none"> • 2100 Watt, 230v motor • Variable speed control with soft start • Collet sizes - 1/4", 3/8" & 1/2" • Includes 15piece boxed router bit set, 16 & 30mm guide bushes, 2 guide rods plus parallel & circular guides <p align="right">Part No. 6462075</p> |

A SELECTION FROM THE VAST RANGE OF

Clarke®

QUALITY PRODUCTS



AIR COMPRESSORS
From DIY to industrial, Plus air tools, spray guns and accessories.

GENERATORS
Prime duty or emergency standby for business, home and leisure.

POWER WASHERS
Hot and cold, electric and engine driven - we have what you need

WELDERS
Mig, Arc, Tig and Spot. From DIY to auto/industrial.

METALWORKING
Drills, grinders and saws for DIY and professional use.

WOODWORKING
Saws, sanders, lathes, mortisers and dust extraction.

HYDRAULICS
Cranes, body repair kits, transmission jacks for all types of workshop use.

WATER PUMPS
Submersible, electric and engine driven for DIY, agriculture and industry.

POWERTOOLS
Angle grinders, cordless drill sets, saws and sanders.

STARTERS/CHARGERS
All sizes for car and commercial use.



PARTS & SERVICE: 0208 988 7400

Parts Enquiries
Parts@clarkeinternational.com

Servicing & Technical Enquiries
Service@clarkeinternational.com

SALES: UK 01992 565333 or Export 00 44 (0)1992 565335

Clarke® INTERNATIONAL Hemnall Street, Epping, Essex CM16 4LG
www.clarkeinternational.com